

PRIMAL

STRENGTH

STEALTH COMMERCIAL FITNESS ELITE
POWER RACK/SMITH
MACHINE/FUNCTIONAL TRAINER ULTRA
SYSTEM. MATTE NERO
PSPR0006

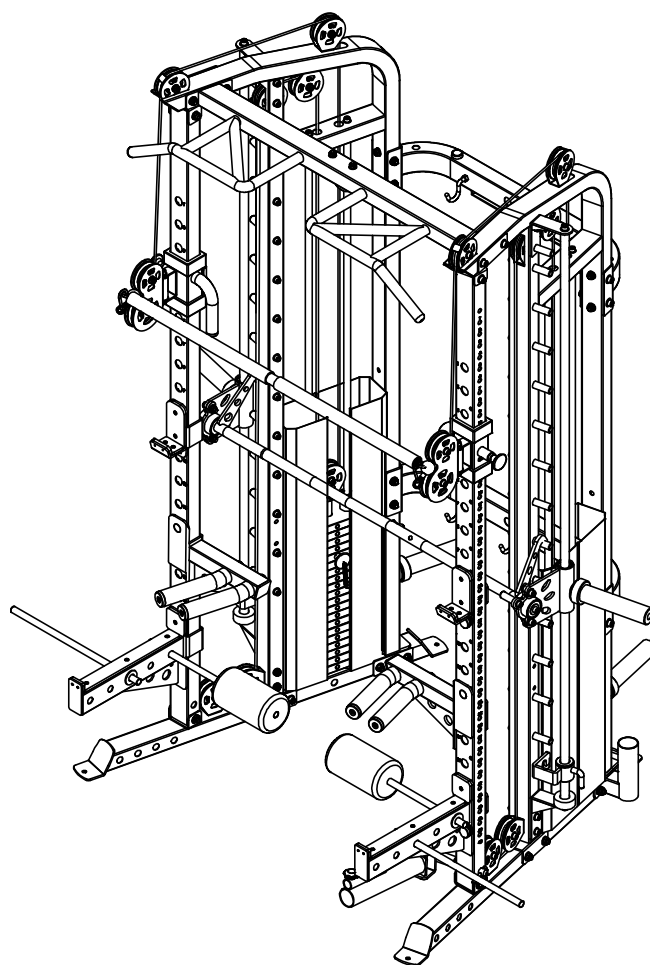

ASSEMBLY INSTRUCTIONS

EXPLODED DIAGRAM 1

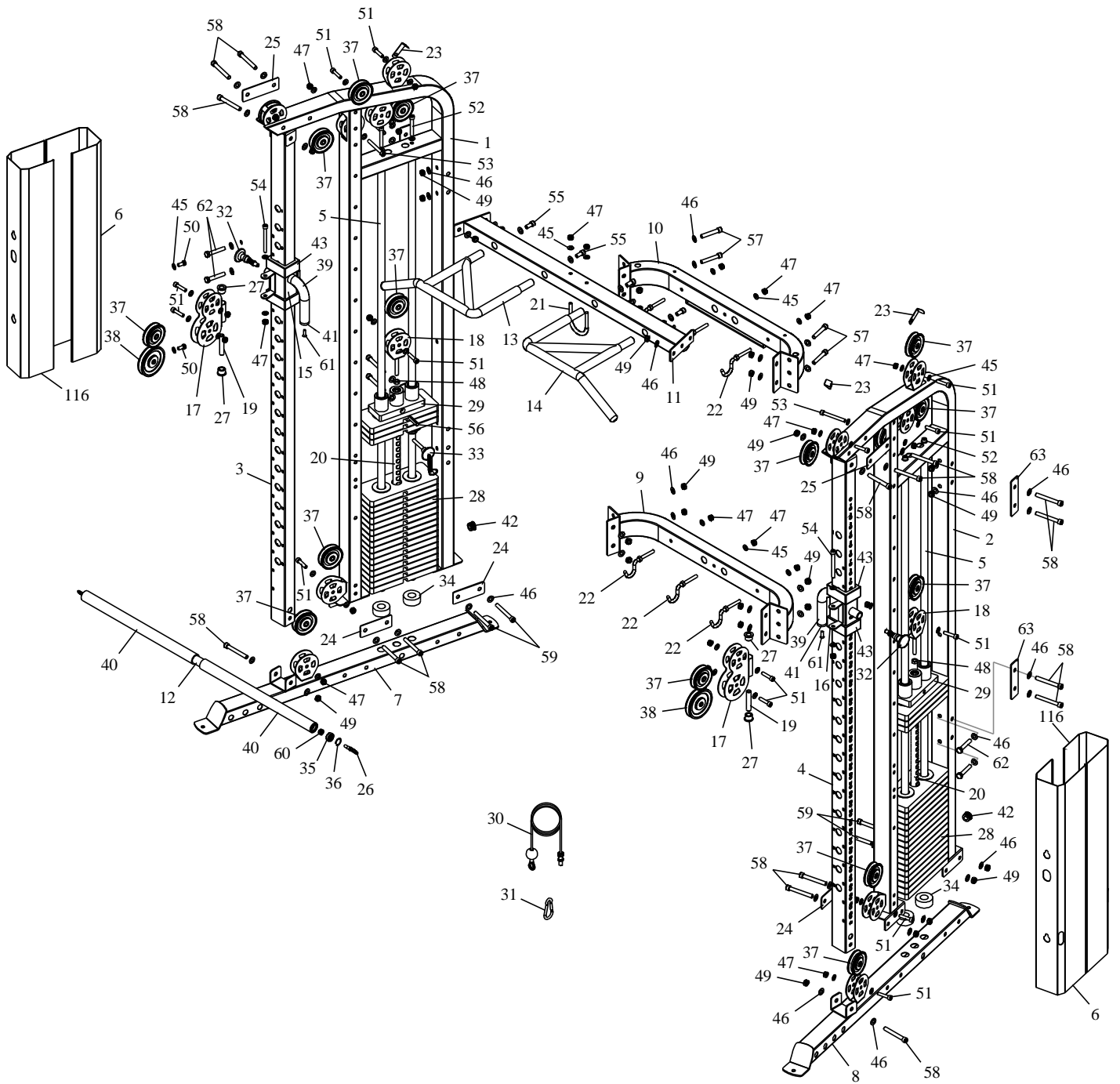

EXPLODED DIAGRAM 2

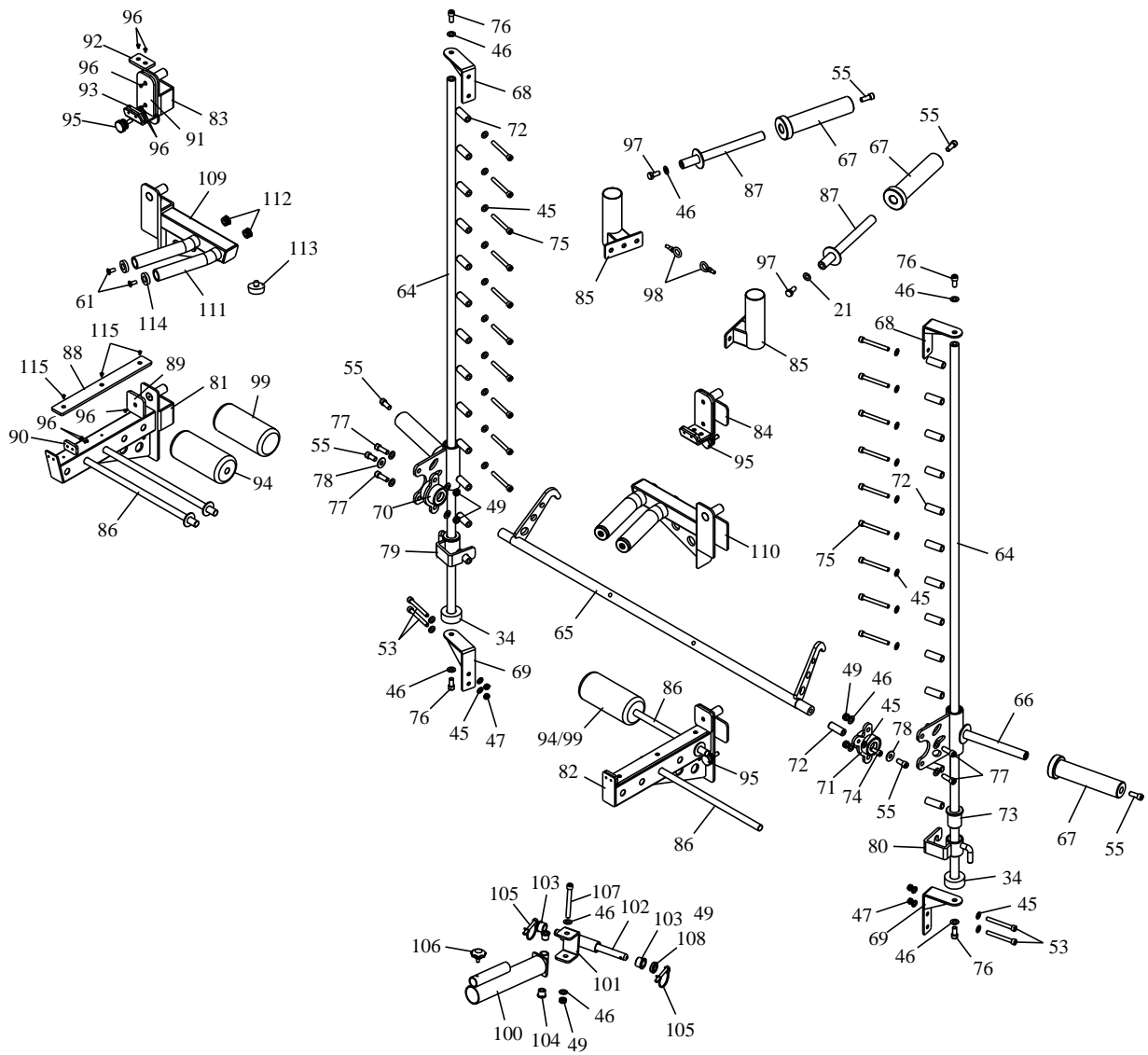

PARTS LISTING AND HARDWARE

KEY NO.	PART DESCRIPTION	SPEC	Q'TY
1	LEFT MAIN UPRIGHT		1
2	RIGHT MAIN UPRIGHT		1
3	LEFT SLIDE FRAME		1
4	RIGHT SLIDE FRAME		1
5	GUIDE ROD		4
6	LEFT SIDE SHELL		2
7	LEFT BASE		1
8	RIGHT BASE		1
9	BOTTOM CROSS FRAME		1
10	MIDDLE CROSS FRAME		1
11	TOP CROSS FRAME		1
12	PULL BAR		1
13	LEFT CHIN UP BAR		1
14	RIGHT CHIN UP BAR		1
15	LEFT SLIDER		1
16	RIGHT SLIDER		1
17	DOUBLE PULLEY BRACKET		2
18	SINGLE PULLEY BRACKET		2
19	AXIS		2
20	WEIGHT SELECTOR		2
21	CLOSED HOOK		1
22	HOOK		6
23	CABLE STOPPER		4
24	REINFORCEMENT PLATE		4
25	LONG REINFORCEMENT PLATE		2
26	CIRCLE HOOK		2
27	COPPER BUSHING		4
28	WEIGHT PLATE		38
29	TOP PLATE		2
30	CABLE		2
31	CLIP		2
32	SLIDER PIN		2
33	WEIGHT SELECT PIN		2
34	RUBBER BUMPER		6
35	BEARING		2
36	CIRCLE FOR HOLE		2
37	PULLEY		16
38	LARGE PULLEY		2
39	FOAM ROLLER		2
40	LONG FOAM ROLLER		2

41	SHEATHING		2
42	ROUND PLUG	32	2
43	GUIDE SLEEVE		4
45	WASHER	10MM	93
46	WASHER	12MM	84
47	LOCK NUT	M10	32
48	NUT	M12	2
49	NYLOCK NUT	M12	37
50	HEXAGONAL HEAD SCREW	M10*20	4
51	SOCKET CAP SCREW	M10*50	16
52	SOCKET CAP SCREW	M10*70	4
53	SOCKET CAP SCREW	M10*90	6
54	SOCKET CAP SCREW	M10*105	2
55	SOCKET CAP SCREW	M12*25	10
56	PIN		2
57	SOCKET CAP SCREW	M12*75	4
58	SOCKET CAP SCREW	M12*95	20
59	SOCKET CAP SCREW	M12*100	4
60	LOCK NUT	M8	2
61	SOCKET SCREW	M8*25	6
62	HEXAGONAL HEAD SCREW	M12*75	4
63	REINFORCEMENT PLATE		4
64	SLIDE ROD		2
65	BAR		1
66	SLIDE PLATE BAR		2
67	OLYMPIC PLATE BAR		4
68	UPPER HOLDER		2
69	BOTTOM HOLDER		2
70	LEFT ROTATIONAL HOLDER		1
71	RIGHT ROTATIONAL HOLDER		1
72	HOOK SUPPORT		29
73	BUSHING		2
74	SOCKET CAP SCREW	M10*30	1
75	SOCKET CAP SCREW	M10*95	28
76	SOCKET CAP SCREW	M12*30	4
77	SOCKET CAP SCREW	M12*35	4
78	BIG WASHER	12MM	2
79	LEFT SAFETY		1
80	RIGHT SAFETY		1
81	LEFT HOLD SUPPORT		1
82	RIGHT HOLD SUPPORT		1
83	LEFT BARBELL SUPPORT		1

84	RIGHT BARBELL SUPPORT		1
85	BAR SUPPORT		2
86	HOLDER		4
87	PLATE BAR		2
88	NYLON PLATE-1		2
89	NYLON PLATE-2		2
90	NYLON PLATE-3		2
91	NYLON PLATE-4		2
92	NYLON PLATE-5		2
93	NYLON PLATE-6		2
94	FOAM ROLLER		2
95	PIN		4
96	SOCKET HEAD SCREW	M5*10	18
97	HEXAGONAL HEAD SCREW	M12*25	2
98	CIRCLE HOOK		2
99	FOAM COVER		2
100	BAR SUPPORT		1
101	ROTATION SUPPORT		1
102	AXIS		1
103	COPPER BUSHING		2
104	SMALL COPPER BUSHING		2
105	LOCK PIN		2
106	PLUM SHAPED SCREW		1
107	SOCKET CAP SCREW	M12*105	1
108	NYLON WASHER		1
109	LEFT SUPPORT		1
110	RIGHT SUPPORT		1
111	FOAM ROLLER		4
112	ROUND PLUG		4
113	RUBBER PAD		2
114	SHEATHING		4
115	SOCKET HEAD SCREW	M5*16	6
116	RIGHT SIDE SHELL		2

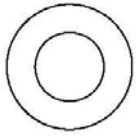

#45 Washer 10 (Qty 93)

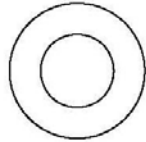

#46 Washer 12 (Qty 84)



#47 M10 Lock Nut (Qty 32)



#48 M12 Nut (Qty 2)

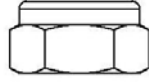

#49 M12 Lock Nut (Qty 37)

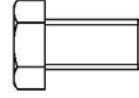

#50 M10 x 20 Hexagonal Screw (Qty 4)



#51 M10 x 50 Socket Cap Screw (Qty 16)

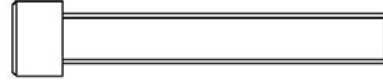

#52 M10 x 70 Socket Cap Screw (Qty 4)

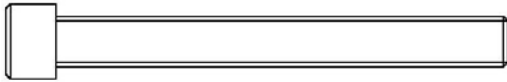

#53 M10 x 90 Socket Cap Screw (Qty 6)

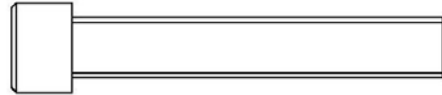

#57 M12 x 75 Socket Cap Screw (Qty 4)

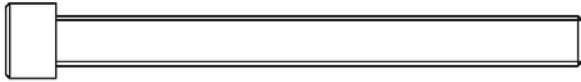

#54 M10 x 105 Socket Cap Screw (Qty 2)

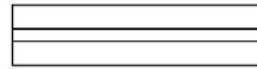

#56 PIN (Qty 2)

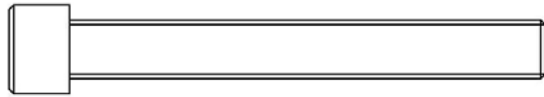

#58 M12 x 95 Socket Cap Screw (Qty 20)

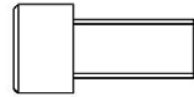

#55 M12 x 25 Socket Cap Screw (Qty 10)

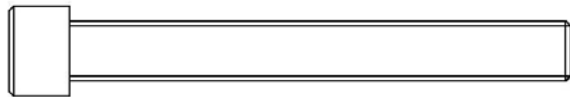

#59 M12 x 100 Socket Cap Screw (Qty 4)

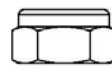

#60 M8 Lock Nut (Qty 2)

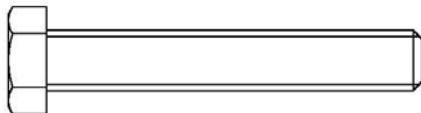

#62 M12 x 75 Hexagonal Screw (Qty 4)

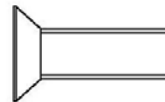

#61 M8 x 25 Socket Screw (Qty 6)



#74 M10 × 30 Socket Cap Screw (Qty 1)

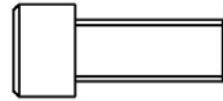

#76 M12 × 30 Socket Cap Screw (Qty 4)



#75 M10 × 95 Socket Cap Screw (Qty 28)

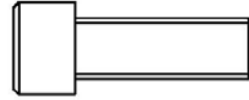

#77 M12 × 35 Socket Cap Screw (Qty 4)

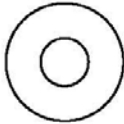

#78 Big Washer 12 (Qty 2)

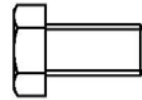

#97 M12 × 25 Hexagonal Screw (Qty 2)

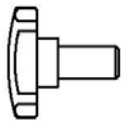

#106 Plum Shaped Screw (Qty 1)



#107 M12 × 105 Socket Cap Screw (Qty 1)



#96 M5 × 10 Socket Head Screw (Qty 18)

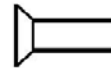

#115 M5 × 16 Socket Head Screw (Qty 6)

ASSEMBLY DIAGRAM 1 USE A PARTNER TO HELP WITH THIS STEP

REMEMBER: Only hand tighten all nuts and bolts until whole machine is assembled

1. Attach the LEFT MAIN UPRIGHT (1) through two REINFORCEMENT PLATES (24) to the LEFT BASE (7), using two SCREWS M12X95 (58) in the front post, two SCREWS M12X100 (59) and the BAR SUPPORT (85) in the rear post, eight WASHERS 12MM (46) and four NYLOCK NUTS M12 (49)
2. Insert a COPPER BUSHING (27) into each end of a DOUBLE PULLEY BRACKET (17). Attach a FOAM ROLLER (39) a SHEATHING (41) and a SOCKET SCREW M8X25 (61) onto the LEFT SLIDER (15). Insert a GUIDE SLEEVE (43) into each end of the LEFT SLIDER (15) *(See the exploded diagram for more detail, Skip this step if pre-assembled)*
3. Attach the DOUBLE PULLEY BRACKET (17) to the LEFT SLIDER (15) using AXIS (19), SCREW M10X105 (54), two WASHER 10MM (45) and LOCK NUT M10 (47)
4. Ensuring correct orientation, slide the assembled LEFT SLIDER (15) onto the LEFT SLIDE FRAME (3), secure with SLIDER PIN (32)
5. Position the LEFT SLIDE FRAME (3) between the LEFT BASE (7) and the LEFT MAIN UPRIGHT (1). Attach each end using two SCREWS M12X95 (58), four WASHER 12MM (46) and two NYLOCK NUTS M12 (49).
6. Insert an OLYMPIC PLATE BAR (67) onto each PLATE BAR (87) and attach using SCREW M12X25 (55) on each
7. Attach CIRCLE HOOK (98) to the LEFT MAIN UPRIGHT (1).

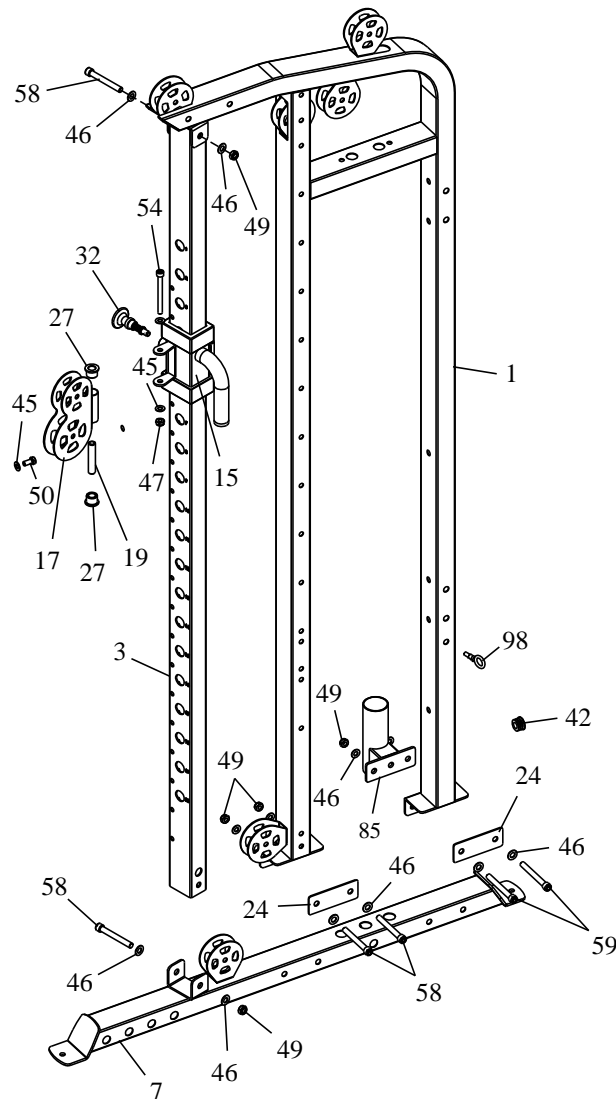

ASSEMBLY DIAGRAM 2 USE A PARTNER TO HELP WITH THIS STEP
REMEMBER: Only hand tighten all nuts and bolts until whole machine is assembled

1. Attach the RIGHT MAIN UPRIGHT (2) through two REINFORCEMENT PLATES (24) to the RIGHT BASE (8), using two SCREWS M12X95 (58) in the front post, two SCREWS M12X100 (59) and the BAR SUPPORT (85) in the rear post, eight WASHERS 12MM (46) and four NYLOCK NUTS M12 (49)
2. Insert a COPPER BUSHING (27) into each end of a DOUBLE PULLEY BRACKET (17). Attach a FOAM ROLLER (39) a SHEATHING (41) and a SOCKET SCREW M8X25 (61) onto the RIGHT SLIDER (16). Insert a GUIDE SLEEVE (43) into each end of the RIGHT SLIDER (16) (*See the exploded diagram for more detail, Skip this step if pre-assembled*)
3. Attach the DOUBLE PULLEY BRACKET (17) to the RIGHT SLIDER (16) using AXIS (19), SCREW M10X105 (54), two WASHER 10MM (45) and LOCK NUT M10 (47)
4. Ensuring correct orientation, slide the assembled RIGHT SLIDER (16) onto the RIGHT SLIDE FRAME (4), secure with SLIDER PIN (32)
5. Position the RIGHT SLIDE FRAME (4) between RIGHT BASE (8) and the RIGHT MAIN UPRIGHT (2). Attach each end using two SCREWS M12X95 (58), four WASHER 12MM (46) and two NYLOCK NUTS M12 (49)
6. Insert an OLYMPIC PLATE BAR (67) onto each PLATE BAR (87) and attach using SCREW M12X25 (55)

on each

7. Attach CIRCLE HOOK (98) to the right MAIN UPRIGHT (2).

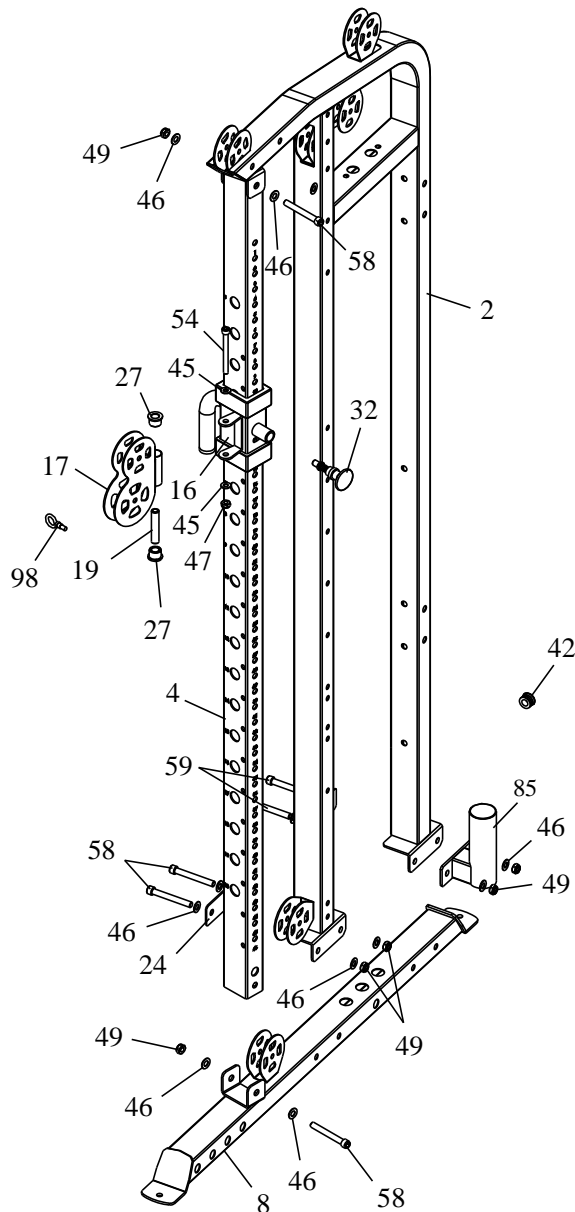

ASSEMBLY DIAGRAM 3 USE A PARTNER TO HELP WITH THIS STEP

REMEMBER: Only hand tighten all nuts and bolts until whole machine is assembled

1. Attach the BOTTOM CROSS FRAME (9) and the REINFORCEMENT PALTE (63) to the rear of the LEFT & RIGHT MAIN UPRIGHTS (1&2) using four HEX SCREW M12X75 (62), four SCREW M12X95 (58), sixteen WASHER 12MM (46) and eight NYLOCK NUT M12 (49)
2. Attach the MIDDLE CROSS FRAME (10) and the REINFORCEMENT PLATE (63) to the upper rear of the LEFT & RIGHT MAIN UPRIGHTS (1&2) using four SCREW M12X75 (57), four SCREW M12X95 (58), sixteen WASHER 12MM (46) and eight NYLOCK NUT M12 (49)
3. Attach six HOOKS (22) to the BOTTOM & MIDDLE CROSS FRAMES (9&10), using six WASHER 10MM (45) and six LOCK NUT M10 (47)
4. Attach the TOP CROSS FRAME (11) through a LONG REINFORCEMENT PLATE (25) at each end, to the cross bar between the LEFT & RIGHT MAIN UPRIGHTS (1&2) using four SCREW M12X95 (58),

eight WASHER 12MM (46) and four NYLOCK NUT M12 (49)

5. Attach the CLOSED HOOK (21) to the underside of the TOP CROSS FRAME (11) using two WASHER 10MM (45) and two LOCK NUT M10 (47)
6. Attach the LEFT & RIGHT CHIN UP BARS (13&14) to the TOP CROSS FRAME (11) using four SCREWS M12X25 (55) and four WASHER 12MM (46)

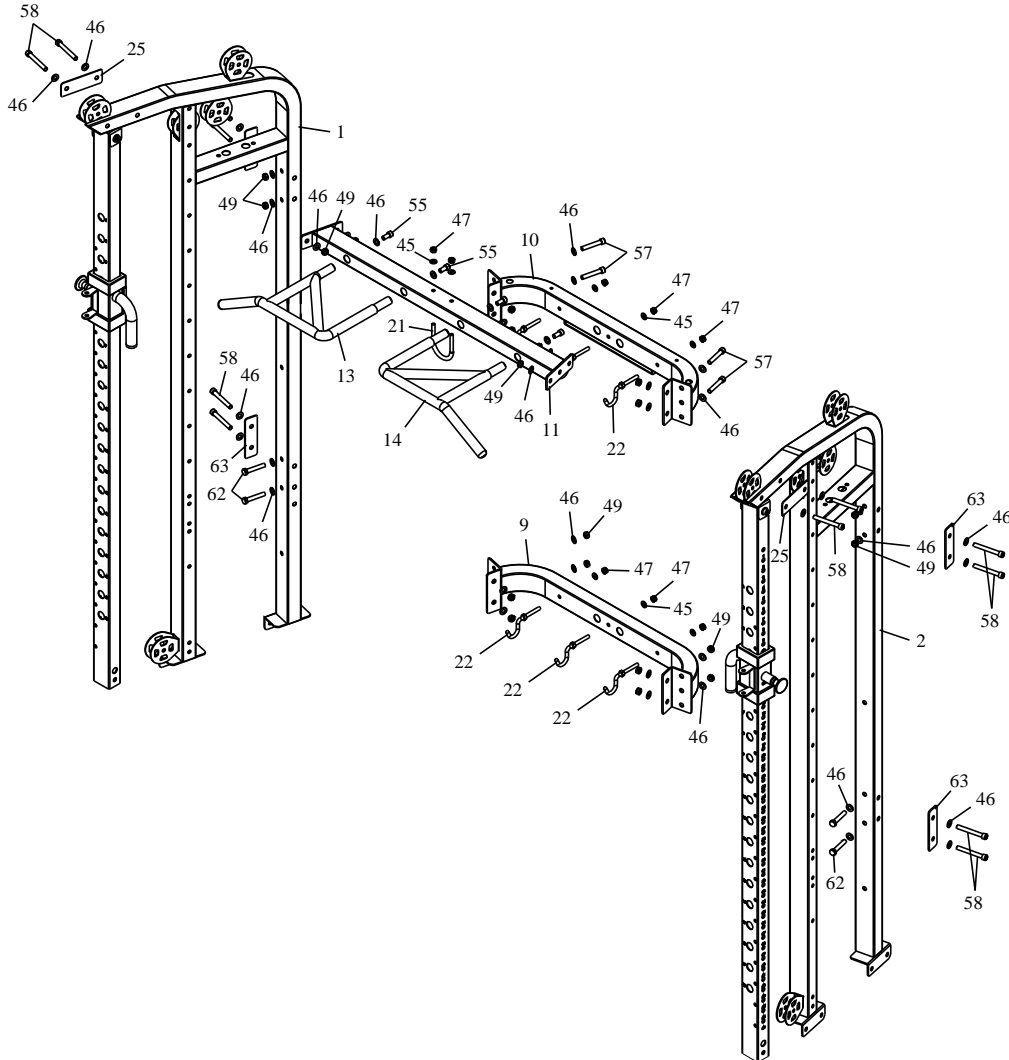

ASSEMBLY DIAGRAM 4 USE A PARTNER TO HELP WITH THIS STEP

REMEMBER: Only hand tighten all nuts and bolts until whole machine is assembled

1. Insert the ends without an attached nut of two GUIDE RODS (5), into the holes on the LEFT BASE (7)
2. Slide a RUBBER BUMPER (34) onto each GUIDE ROD (5)
3. Ensuring correct orientation, slide 19 of the WEIGH PLATES (28) onto the GUIDE RODS (5)
4. Insert the WEIGHT SELECTOR (20) into the central hole of the WEIGHT PLATES (28). Insert a WEIGHT SELECTOR PIN (33) through a weight, into the WEIGHT SELECTOR (20)
5. Slide a TOP PLATE (29) onto the GUIDE RODS (5). Secure the TOP PLATE (29) to the WEIGHT SELECTOR (20) using a pin (56)
6. Ensuring correct orientation, attach the SIDE SHELL (6&116) between the rear posts of the RIGHT MAIN UPRIGHT (2), using two HEX SCREWS M10X20 (50) and two WASHERS 10MM (45)
7. Attach the PLATE BAR (87) to the holes on the lower rear of the *LEFT & RIGHT MAIN UPRIGHTS*

using a HEX SCREW M12X25 (97) and a WASHER 12MM (46) on each

8. Thread a NUT M12 (48) onto the SINGLE PULLEY BRACKET (18). Insert the SINGLE PULLEY BRACKET (18) into the WEIGHT SELECTOR (20). Do not tighten! This will be adjusted later.
9. Secure the top of GUIDE RODS (5) to the LEFT MAIN UPRIGHT (1) using two SCREW M10X65 (52)
10. Attach eight PULLEY (37) and one LARGE PULLEY (38) (At point B), into the pulley brackets using eight SCREWS M10X50 (51), sixteen WASHER 10MM (45) and eight LOCK NUT M10 (47)

Note: 1. Make sure the two CABLE STOPPERS (23) are attached at pulleys A.

2. At point C don't assemble pulley now

11. Repeat the above steps to assemble the right side of the machine

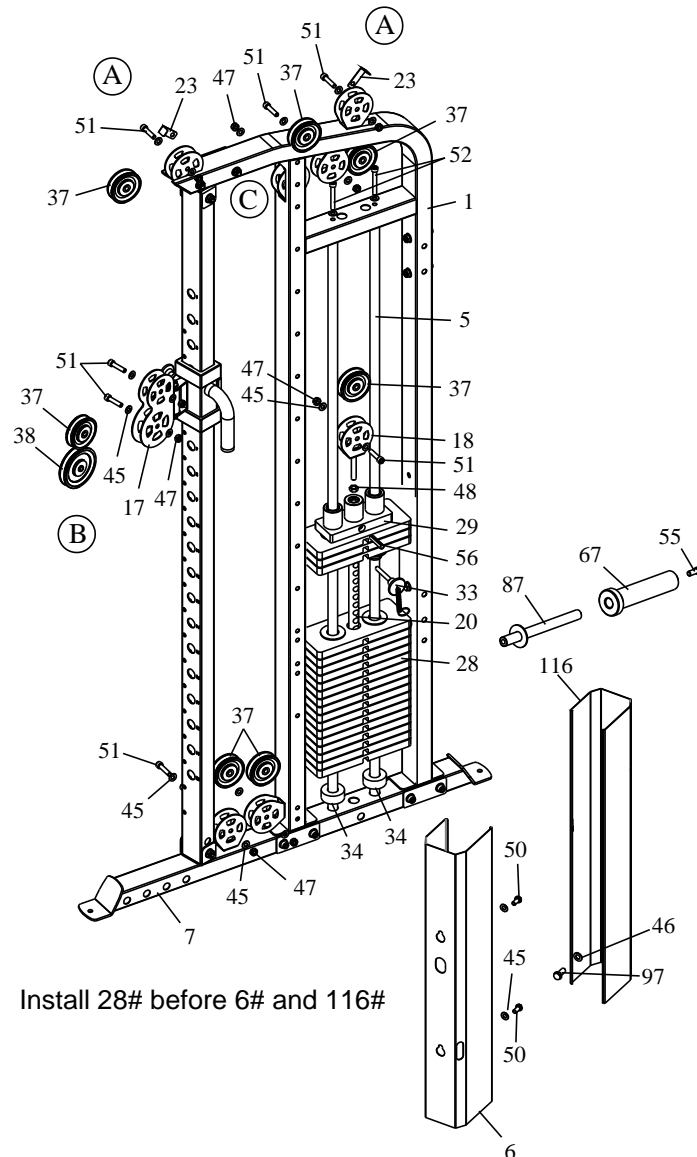

ASSEMBLY DIAGRAM 5 USE A PARTNER TO HELP WITH THIS STEP

REMEMBER: Only hand tighten all nuts and bolts until whole machine is assembled

1. Insert a SCREW M10X90 (53) through a WASHER 10MM (45) into the top hole in the *RIGHT MAIN UPRIGHT (2)*
2. Insert a SCREW M10X95 (75) through a WASHER 10MM (45) into each hole in the *RIGHT MAIN UPRIGHT (2)*, the point of second top screw should through a PULLEY (37)

3. Ensuring correct orientation, pass the top two screws through an UPPER HOLDER (68). Attach a WASHER 10MM (45) and a LOCK NUT M10 (47) over the end of the top screw. Attach a HOOK SUPPORT (72) over the end of each screw
4. Attach a BOTTOM HOLDER (69) to the two lowest holes on the *RIGHT MAIN UPRIGHT (2)* using two SCREW M10X90 (53), four WASHER 10MM (45) and two LOCK NUT M10 (47)
5. Attach BUSHING (73) to LEFT AND RIGHT SAFETY (79&80). Ensuring correct orientation, slide RUBBER BUMPER (34) and the LEFT AND RIGHT SAFETY (79&80) onto each SLIDE ROD (64) (*Skip this step if pre-assembled*)
6. Slide a SLIDE PLATE BAR (66) onto the SLIDE ROD (64). Insert an OLYMPIC PLATE BAR (67) over the SLIDE PLATE BAR (66), attach using two SCREW M12X25 (55)
7. Ensuring correct orientation, position the SLIDE ROD (64) between the UPPER & BOTTOM HOLDERS (68&69). Attach using a SCREW M12X30 (76) and a WASHER 12MM (46) at each end (*Skip this step if pre-assembled*)
8. Position the BAR (65) between both ROTATIONAL HOLDERS (70&71) and attach each end using a SCREW M12X25 (55) and a BIG WASHER 12MM (78)
9. Attach the RIGHT ROTATIONAL SHOULDER (71) into the SLIDE PLATE BAR (66) using two SCREW M12X35 (77), four WASHER 12MM (46) and two LOCK NUT M12 (49)
10. Follow the same steps to assemble to left side
11. Attach a HOOK SUPPORT (72) to the RIGHT ROTATIONAL SHOULDER (71) using a SCREW M10X30 (74) and a WASHER 10MM (45)

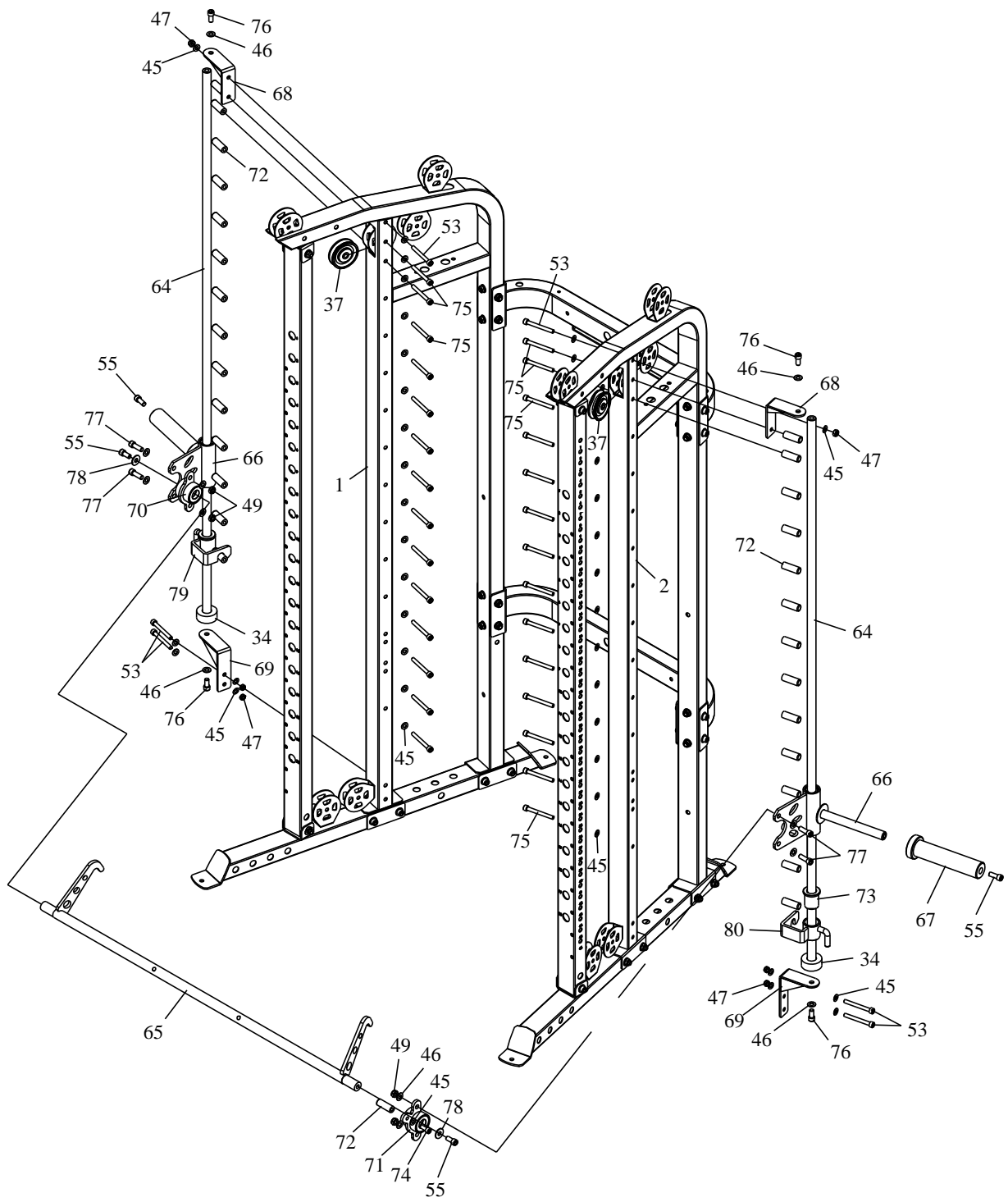

ASSEMBLY DIAGRAM 6 USE A PARTNER TO HELP WITH THIS STEP

REMEMBER: Only hand tighten all nuts and bolts until whole machine is assembled

1. Bring the threaded end of a CABLE (30) from A→B→C→D→E→F→G→H→15.
2. Repeat the steps to route the cable through the opposite side.
3. Assemble the PULL BAR (12) by attaching two LONG FOAM ROLLERS (40), using two LOCK NUTS M8 (60), two BEARINGS (35), two CIRCLE FOR HOLES (36) and two CIRCLE HOOKS (26) (*See the exploded diagram for more detail, skip this step if pre-assembled*)
4. Attach the PULL BAR (12) to the end of both CABLE (30) with a CLIP (31)

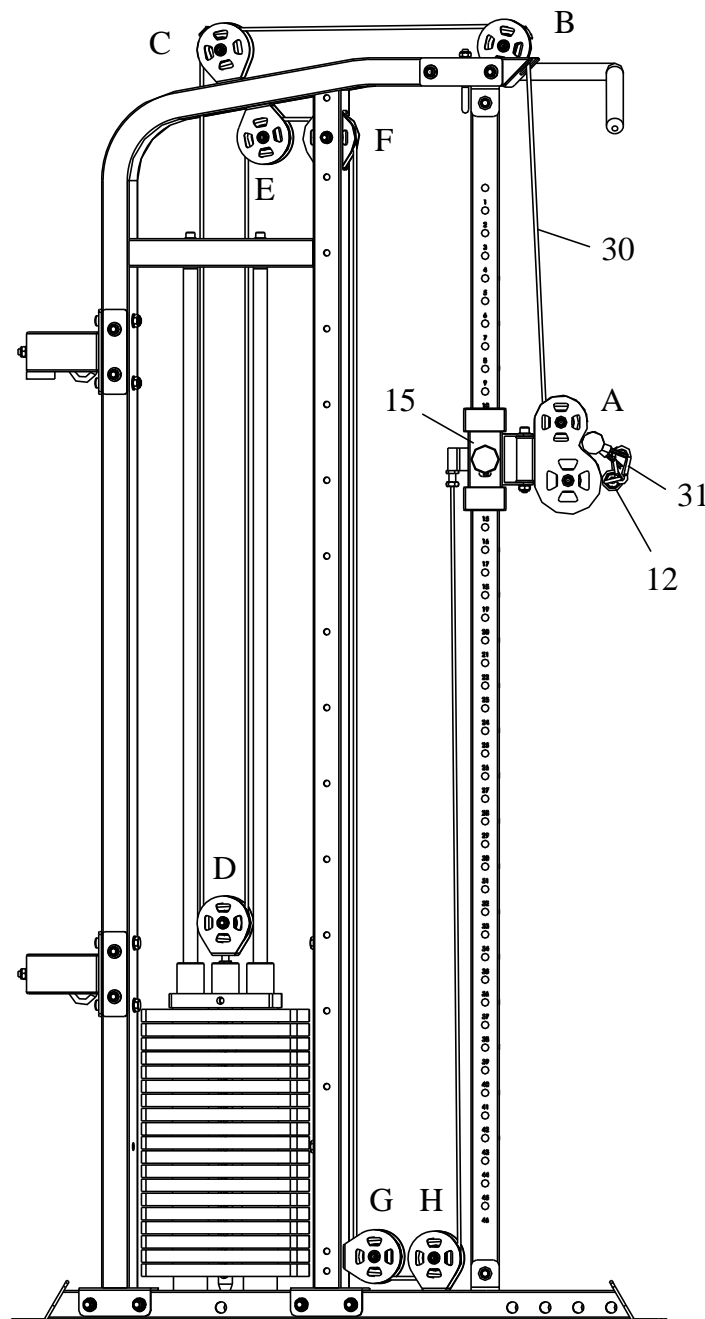

ASSEMBLY DIAGRAM 7 USE A PARTNER TO HELP WITH THIS STEP

REMEMBER: Only hand tighten all nuts and bolts until whole machine is assembled

1. Attach the HOLD SUPPORTS (81&82) to the front of the *SLIDE FRAMES (3&4)* using two PINS (95)
2. Insert a HOLDER (86) through a frontal hole on the LEFT HOLD SUPPORT (81). Slide a FOAM ROLLER (94) and a FOAM COVER (99) onto the HOLDER (86)
3. Repeat the above steps to assemble the RIGHT HOLD SUPPORT (82)
4. Attach the BARBELL SUPPORTS (83&84) to the front of *SLIDE FRAMES (3&4)* using two PINS (95)
5. Attach the LEFT & RIGHT SUPPORTS (109&110) to the front of *SLIDE FRAMES (3&4)*
6. Insert the RUBBER PADS (113) into the hole in MIDDLE CROSS FRAME (10).
7. Insert a SMALL COPPER BUSHING (104) into each open end of the rear of the BAR SUPPORT (100) (*Skip this step if pre-assembled*)
8. Position the BAR SUPPORT (100) in the bracket of the ROTATION SUPPORT (101) and attach using a SCREW M12X105 (107), two WASHER 12MM (46) and a LOCK NUT M12 (49)
9. Insert a COPPER BUSHING (103) into each open end of the ROTATION SUPPORT (101) (*Skip this step if pre-assembled*)
10. Slide the AXIS (102) through the ROTATION SUPPORT (101) and also through a NYLON WASHER (108) and a hole on the RIGHT BASE (8).
11. Secure each axis end with a LOCK PIN (105)
12. Insert a PLUM SHAPED SCREW (106) into the top of the BAR SUPPORT (100)
13. You can put the BARBELL SUPPORTS (83&84) to the BOTTOM CROSS FRAME (9) for storage, and put the HOLD SUPPORTS (81&82) and the LEFT & RIGHT SUPPORTS (109&110) to the MIDDLE CROSS FRAME (10) for storage
14. You can insert HOLDER (86) into holes in the MIDDLE CROSS FRAME (10) and the CIRCLE HOOK (98) for storage

